

CONNESSIONE A TERRA DELL' ARCO - TIPO 1 -

Show-room Diesel - Londra, 2002 - progetto di Favero & Milan Ingegneria

fonte: Favero & Milan Ingegneria

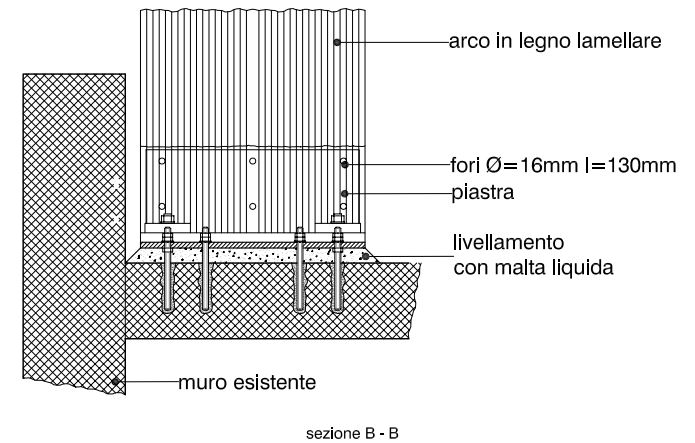
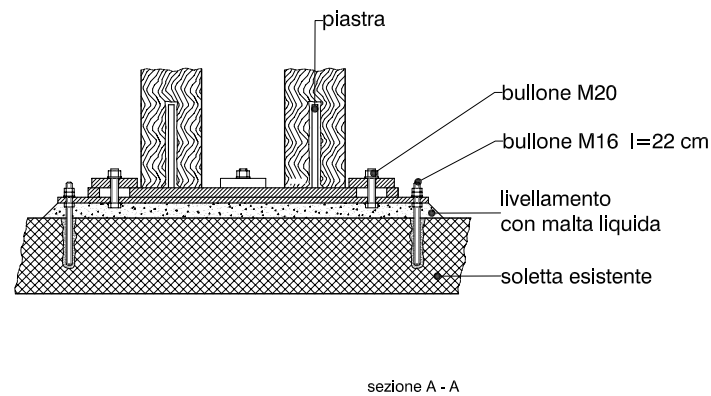
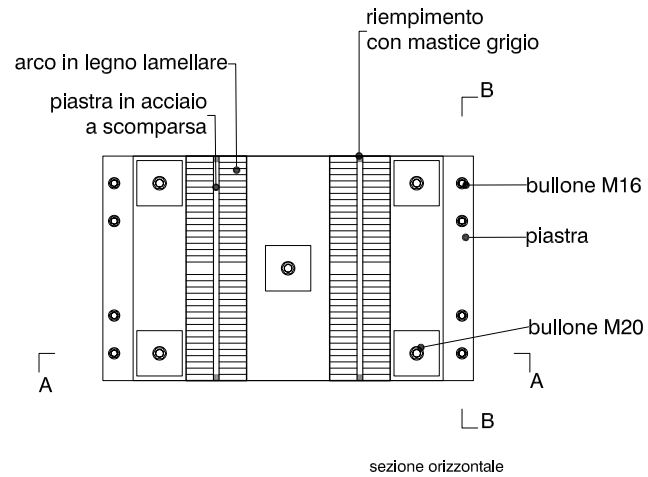
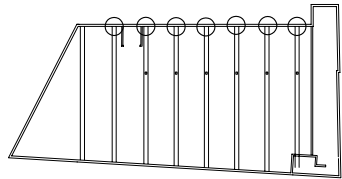

0 20 40 60 cm scala 1:20